



INTEGRATED SUBASSEMBLIES



**TELEDYNE COUGAR**  
A Teledyne Technologies Company

## INTEGRATED SUBASSEMBLIES

Cougar provides basic building blocks for designing higher level assemblies, including Digitally Tuned Oscillator (DTO), Instantaneous Frequency Measurement receiver (IFM), and Frequency Locked Source (FLO) technologies. Cougar uses these core building blocks plus digital processing, microprocessor control and digital signal analysis, to provide higher level assemblies, for example:

- Receiver-jammer unit utilizing an IFM and DTO to build a Set-on Receiver (SOR). The SOR identifies threat-radar signals, transmitting a modulated jamming signal on the same frequency within 250ns. The unit is microprocessor controlled and fully programmable.
- Frequency Locked Source (FLO) covering the 6-18 GHz band, and tuning to any frequency in less than 1µs with a frequency accuracy of <1 MHz under all conditions. The FLO includes pulse, FM, amplitude and phase modulators.
- Deception Jammer front-end covering the 2-18 GHz band in desired frequency blocks. This modular assembly provides up-down frequency conversion, signal identification, emitter priority, signal tracking, predictor gates and transmitter power management. It also prioritizes multiple deception devices (for example, SOR and or DRFM).

### DIGITALLY TUNED OSCILLATORS (DTO)

Cougar offers a complete line of DTOs covering the 0.5 to 18 GHz band. These assemblies tune to any frequency within less than 1µs, and provide very good post tuning drift and settling time performance. Linearized FM is also provided. The DTOs are available in both single or wide band (2-18 GHz).

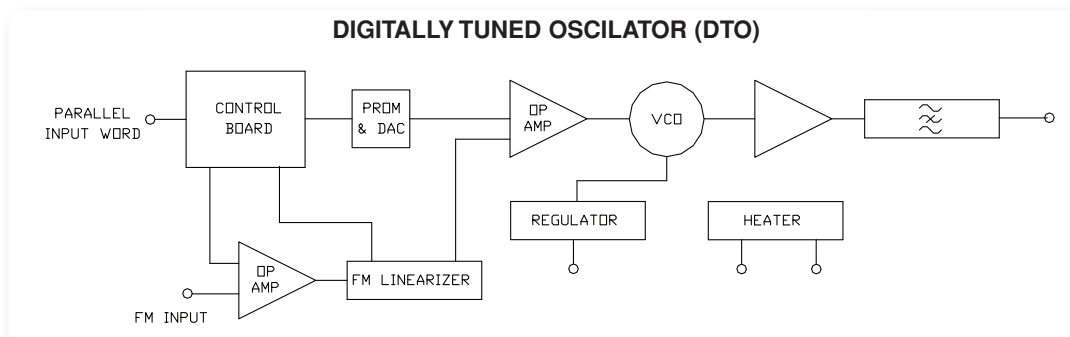

## SET-ON-RECEIVER (SOR)

The SOR provides wideband, fast frequency set-on for EW radar jamming, particularly effective for jamming frequency hopping radars. The SOR consists of an IFM receiver, digitally tuned oscillator (DTO) and a microprocessor controller measuring the threat radar signal frequency within 80ns of transmission. The noise modulated DTO tunes to the same frequency within 250ns. Frequency jamming priority, jam time, look through, power output and noise spot width can be programmed and stored in the SOR.

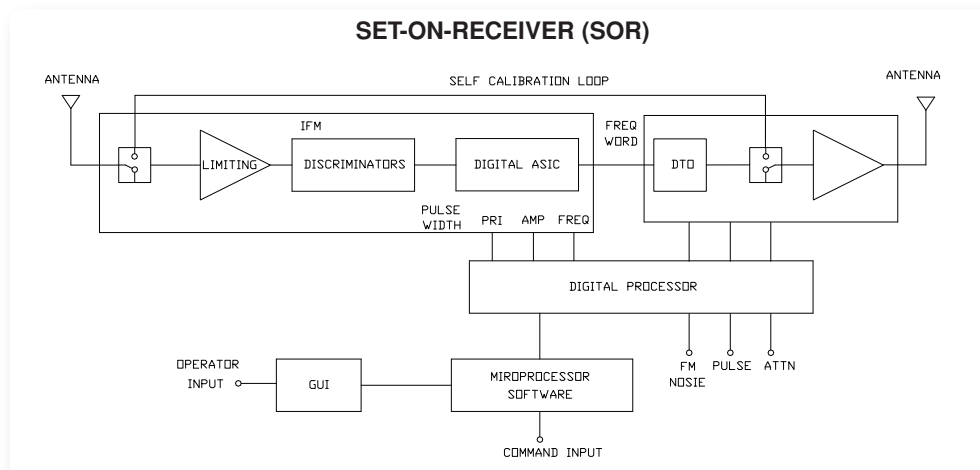
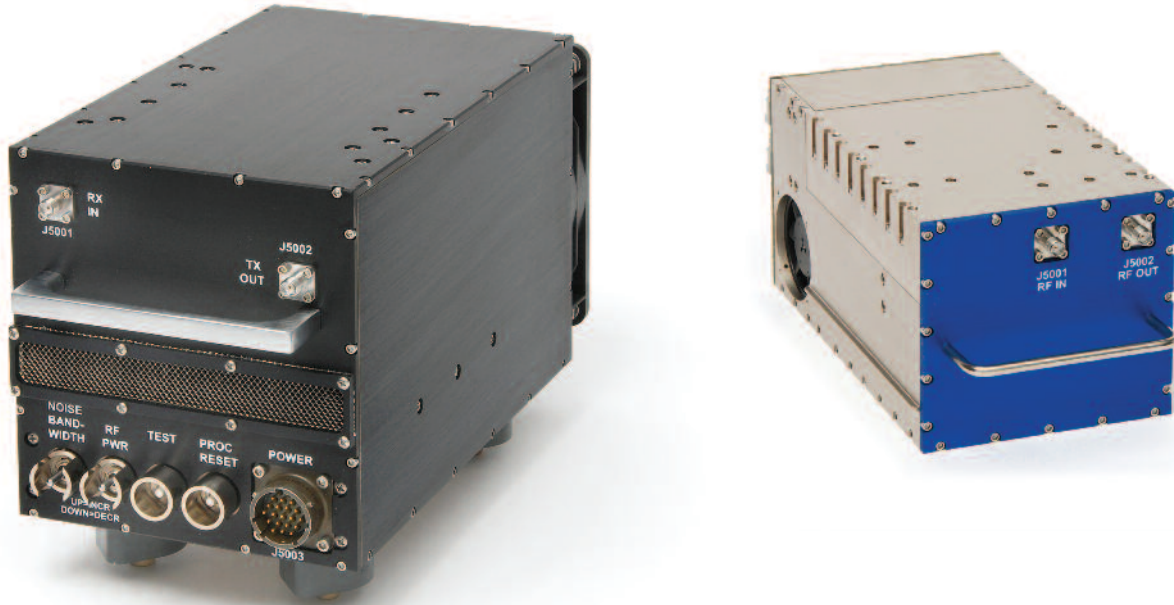

## FREQUENCY LOCKED OSCILLATOR (FLO)

Teledyne developed the FLO for the EW market. The FLO provides substantially better performance than a conventional Digitally Tuned Oscillator (DTO), including improved settling time (PTD) for tuning speeds less than  $1\mu s$ , frequency accuracy of  $<1\text{MHz}$  under all conditions, and improved phase noise. The FLO can be frequency modulated in either the open or closed loop mode. Single band and multi-band coverage is available covering the 2-18 GHz band.



### FREQUENCY LOCKED OSCILLATOR (FLO)

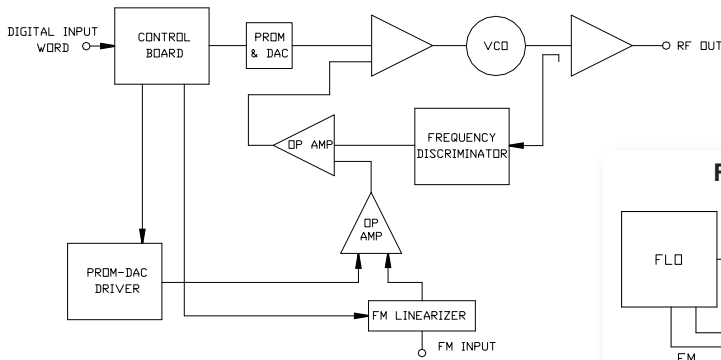

### FREQUENCY LOCKED OSCILLATOR (FLO) ASSY

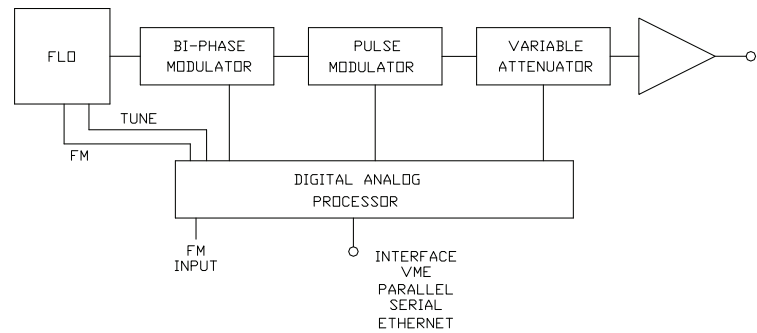

### WIDE BAND FLO ASSY

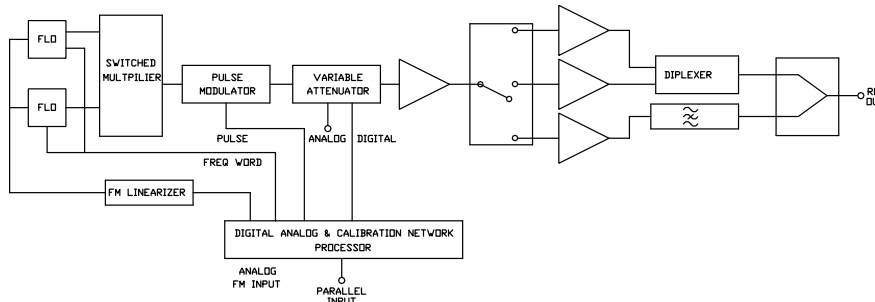

## INSTANTANEOUS FREQUENCY MEASUREMENT (IFM)

Teledyne Instantaneous Frequency Measurement (IFM) capability is utilized in subassemblies that require fast and accurate frequency measurement for either identification or verification applications. Typical applications require not only frequency measurement but Pulse Repetition Rate (PRI) and Pulse Width (PW) measurements as well. Teledyne's IFM capability also allows for measurement of frequency modulation (FMOP) and phase modulation (PMOP). When used in conjunction with Teledyne's SDLVA capability, a complete radar pulse descriptor word is generated for further processing. Teledyne also manages to conform to unique subassembly interface requirements.



### INSTANTANEOUS FREQUENCY MEASUREMENT (IFM)

